



ZANOTTI Spa
 Via M.L. King, 30
 46020 - Pegognaga (MN) - ITALY
 Tel. +39 0376 5551
 Fax +39 0376 536554
 info@zanotti.com

Technical specifications

Version 2.0

Model: **BGM220DB11XA** Class: **GM**

Technical data

Characteristics	M.U.	Value
Working temperature	°C	-15 ÷ -25
Starting mode		Direct
Voltage	Volt-Ph-Hz	400/3N/50
Rated input	kW*	1,50
Rated input	Amp*	4,10
Peak current	Amp	27,0
Max current	Amp	8,0
Refrigerant		R452A
	GWP	2140
Defrost		Hot gas
Mass	Kg	80

Compressor

Type		Hermetic
Nominal power	kW	1,5

Condenser

Air flow	m³/h	1200
----------	------	------

Evaporator

Air flow	m³/h	1200
Air throw	m**	4

PED Category		0
--------------	--	---



Power data

Tc °C	Ta °C	P watt	P Kcal/h	V120 m³	V100 m³	V80 m³
	20	2235	1922	23	20	18
	25	2104	1809	21	19	16
-15	30	1970	1694	18	16	14
	35	1834	1577	17	15	13
	40	1697	1459	15	13	12
	45	1559	1341	13	12	10
	20	1923	1654	17	15	13
	25	1804	1551	17	15	13
-20	30	1688	1452	15	13	12
	35	1567	1348	13	12	10
	40	1432	1232	12	11	9,4
	45	1275	1096	9,5	8,5	7,4
	20	1603	1379	14	12	11
	25	1481	1274	12	11	9,4
-25	30	1361	1170	11	9,8	8,6
	35	1246	1072	9,2	8,2	7,2
	40	1143	983	7,9	7	6,2
	45	1057	909	7	6,2	5,5

Calculation of the refrigerating power and volume

Ta
 °C

Tc
 °C

PF
 Watt

Kcal/h

V120
 m³

V100
 m³

V80
 m³

* When normally running: -20 ÷ +30°C

** Use air throw as a base. Air throw is affected by many factors such as height of room, product storage, location of evaporator, etc.

Tc: Coldroom temp. - Ta: External temp.

P: Refrigerant capacity - V: Recommended cold-room volume

L'immagine è datata e potrebbe presentare alcune differenze rispetto all'unità attuale. La aggiorneremo il prima possibile.
The picture is old and it could have some differences from the current unit. We will update it as soon as possible.

Dimensioni - Dimensions - Dimensions
Abmessungen - Dimensiones

GM2

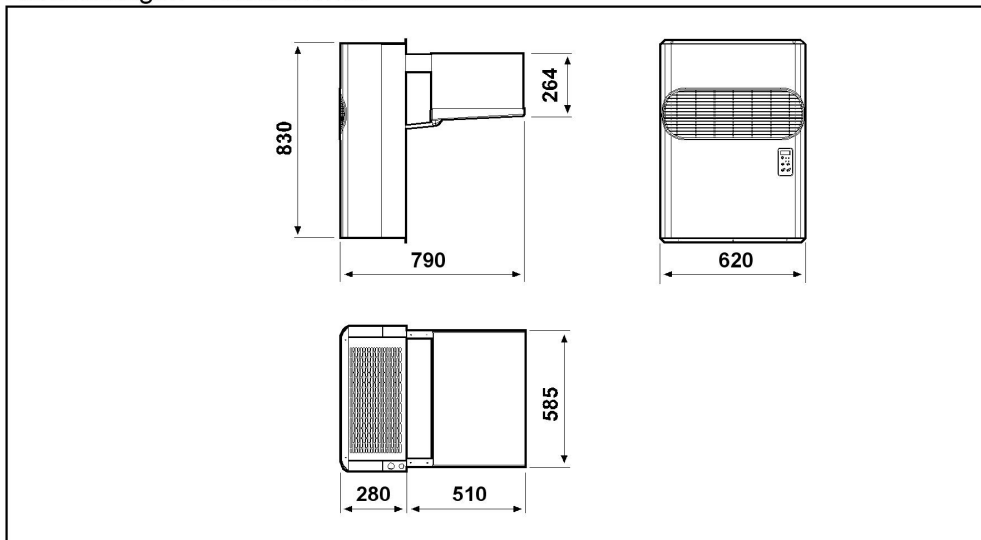

Schema di montaggio - Mounting scheme - Schema de montage
Montageschema - Esquema de montaje

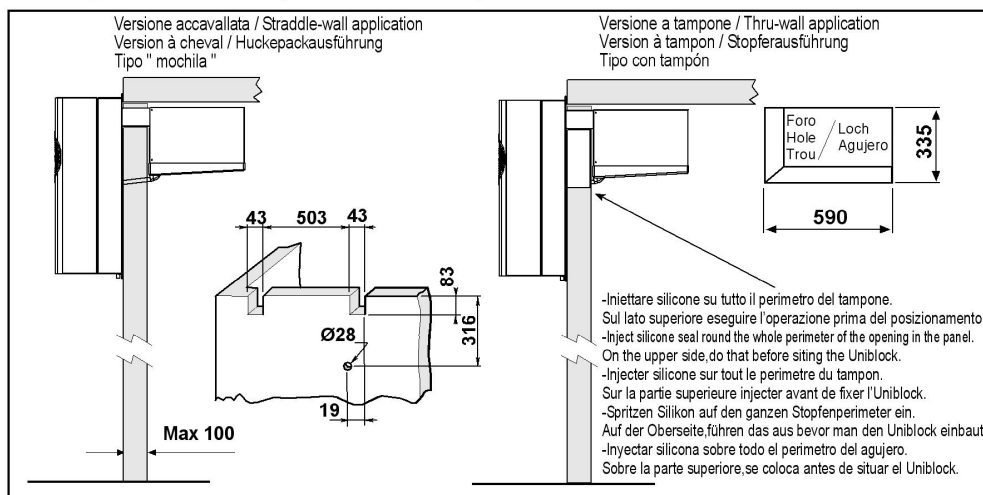

- * Raccomandazioni in sede di installazione e per il controllo fornite sul manuale di installazione
- * To be advised at time of order for factory installation and operating instructions
- * Recommendations au moments d'installations et pour le contrôle fournis sur le manuel d'installation
- * Empfehlungen für die Installationsphase und zur Kontrolle, die im Handbuch zur Installation enthalten sind
- * Por cuanto respecta a recomendaciones de instalación y control ver manual de instalación

Massa e misure imballi - Packing mass and dimensions - Masse et dimensions emballages
Verpackungsmasse und-abmessungen - Masa y medidas del embalaje

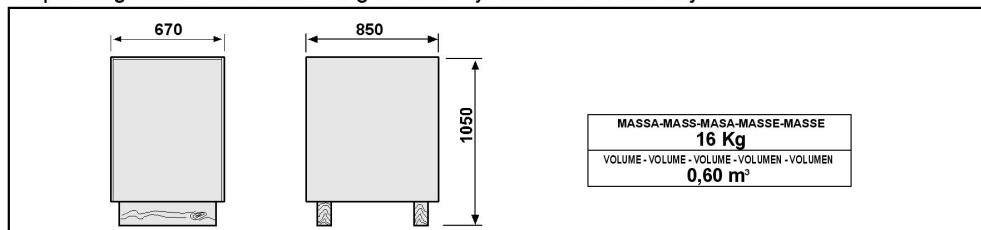

ZANOTTI S.p.A.